

Electrical Engineering Fundamentals

Parallel Circuits

ADVANCED



UNIVERSITY
OF WOLLONGONG
AUSTRALIA

Faculty of Engineering and
Information Sciences

Brendan Banfield & Sasha Nikolic - 2017 - Revised by Faisal Tubbal - 2018

Parallel Circuit

Elements 1, 2 and 3 have terminals **A** and **B** in common; they are therefore connected in parallel. The voltage across elements 1, 2 and 3 is the same and equals to the voltage across terminals **A** and **B**.

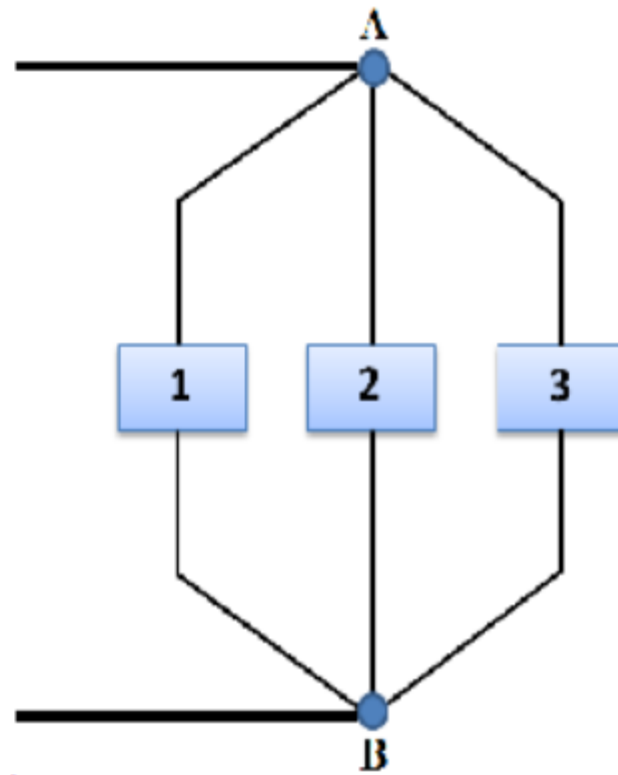

Parallel Circuit

The applied voltage V_{AB} is the same across parallel branches.

The points B, D, F and G are connected to ground and equal to Zero.

The DC voltage supply and three resistors (R_1 , R_2 and R_3) are connected in parallel, therefore $V_A=V_C=V_E=V_H=5V$.

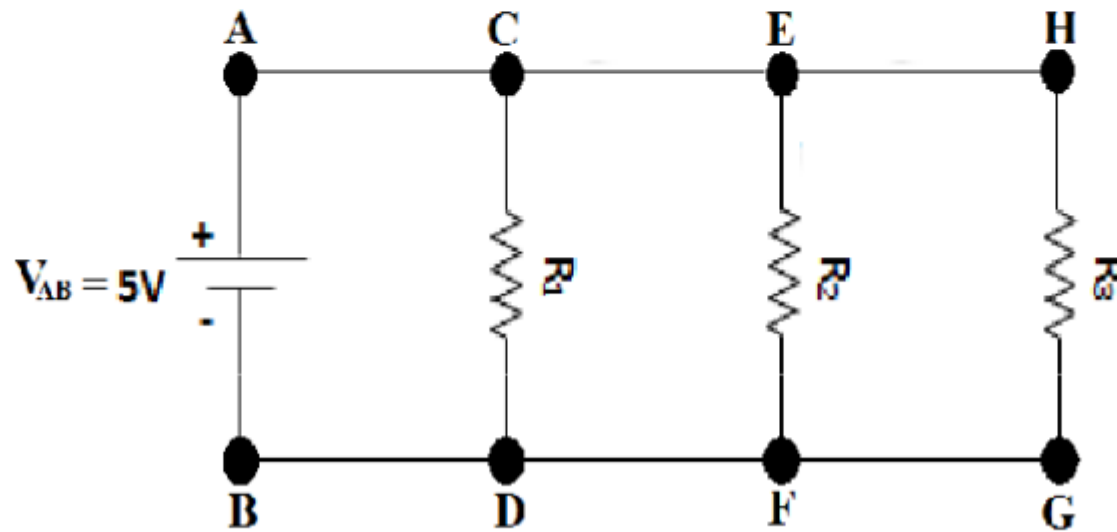

Parallel Circuit

The current in parallel circuit equals the voltage applied across the circuit divided by the resistance between the two points where the voltage applied.

Each path for current in a parallel circuit is called branch; i.e., branched **CD**, **EF** and **HG**.

Each branch current equals V/R , where V in a parallel circuit is the same across all branches.

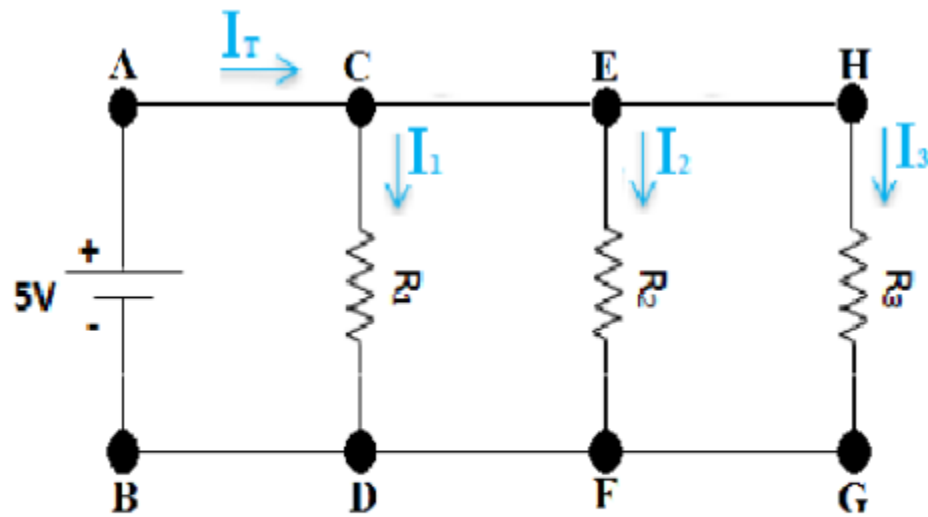

Kirchhoff's Current Law

KCL states that the algebraic sum of the currents into a node is zero.

A **node** is a junction that connects two or more branches (represented below by the circle).

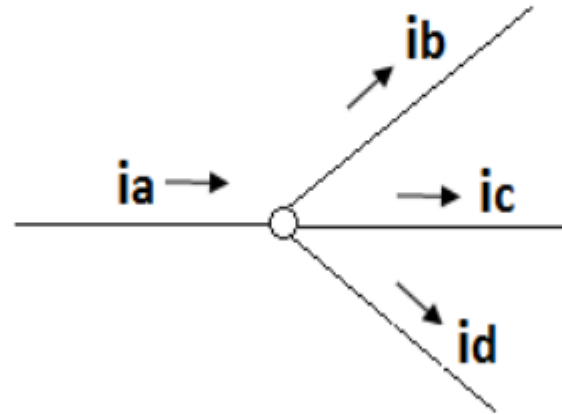

$$i_a - i_b - i_c - i_d = 0$$

Kirchhoff's Current Law

For basic circuits, as the one shown below, it is easier to grasp the concept of KCL as shown below. That is, **the sum of the currents entering a node is equal to the sum of currents leaving a node.**

A good analogy for current is water flowing through a pipe. If a pipe has 7 litres per second flowing through it and the pipe splits in two with one pipe carrying 5 litres per second, the other pipe must have 2 litres per second flowing through it ($7\text{L/s} = 5\text{L/s} + 2\text{L/s}$).

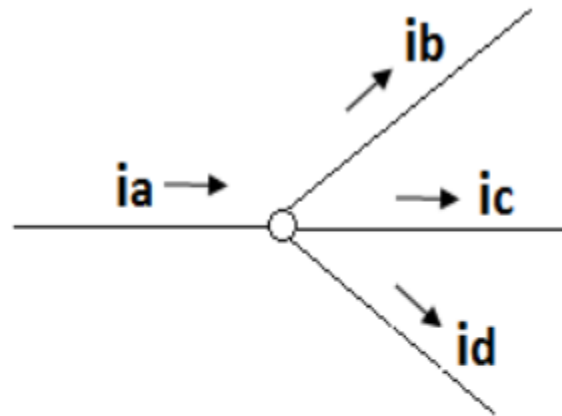

$$i_a = i_b + i_c + i_d$$

Question 1

Question 1 of 6

What is the value of i_b ?

✓ 3A

Correct: The sum of the currents entering a node is equal to the sum of currents leaving a node. $i_b = 10A - 5A - 2A = 3A$.

2A

10A

5A

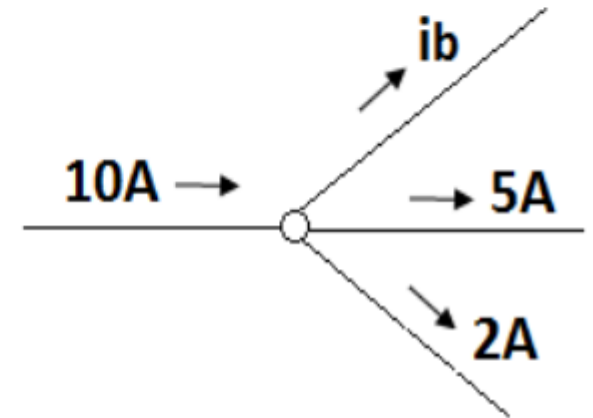

[Click here to continue](#)

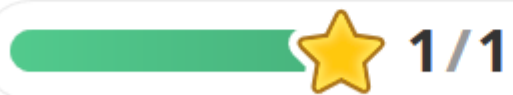

Question 2

Question 2 of 6

Consider the following circuit. You will determine the current I_2 .

True or False. The voltage across each resistor will be different

✓ False

Correct - Resistors in parallel experience the same voltage

True

[Click here to continue](#)

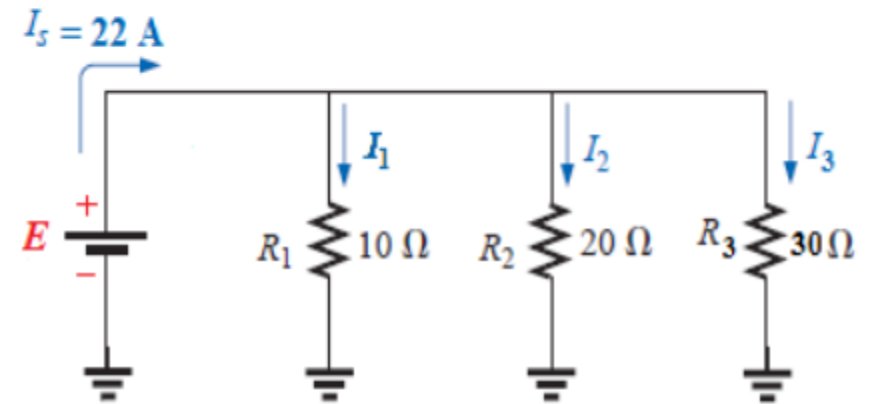

Question 3a

Question 3a of 6

As the source voltage E is unknown, we cannot simply determine I_2 using Ohm's law. We therefore must determine the total resistance R_T first to determine the value of total voltage E . What is the value of R_T ?

✓ 5.4545 Ω

Correct - $R_T = 1/(1/R_1 + 1/R_2 + 1/R_3) = 1/(1/10 + 1/20 + 1/30)$

60 Ω

0.183 Ω

[Click here to continue](#)

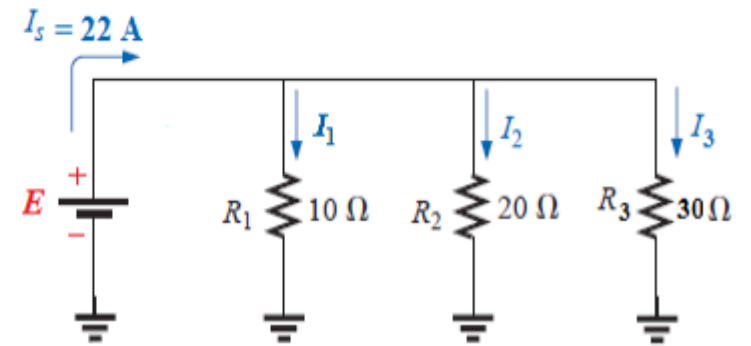

1/1

Question 3b

Question 3b of 6

Given that the determined $R_T = 5.4545\Omega$ and given $I_S = 22\text{ A}$, using ohms law, determine the value of the source voltage E (to the nearest whole number).

✓ 120V

Correct

12V

40V

[Click here to continue](#)

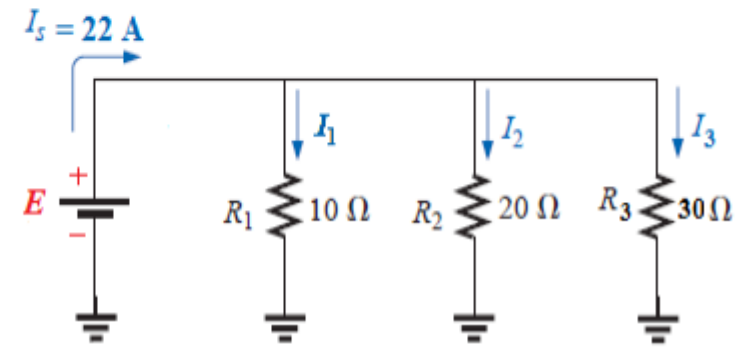

Parallel Circuit

From the previous slide you found that $E = 120 \text{ V}$. This means that the voltage across each of the parallel resistors is also 120 V with respect to ground (0 V).

As the values of each resistor and the voltage across each resistor are known, you are able to determine the current in each branch using Ohm's law. An example finding the current I_1 that flows through R_1 is shown below.

$$V_1 = I_1 R_1$$

$$I_1 = \frac{V_1}{R_1} = \frac{120 \text{ V}}{10 \Omega}$$

$$I_1 = 12 \text{ A}$$

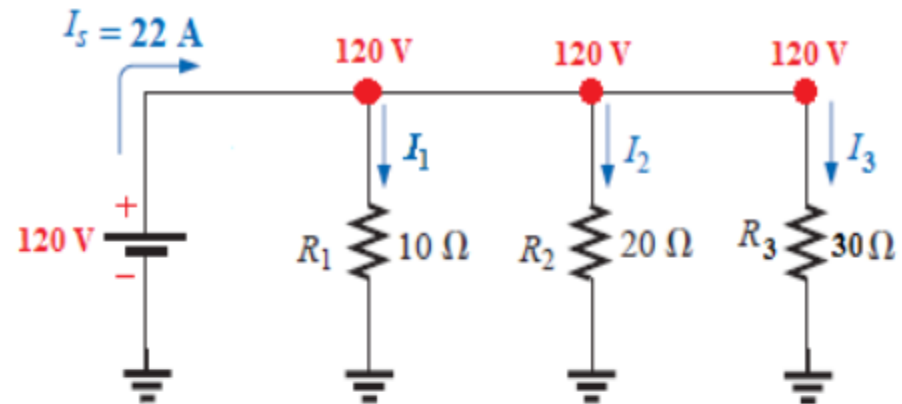

Current Divider Rule

In the last example, to determine the current through each resistor in parallel circuit, you had to determine the total circuit resistance and subsequently the voltage across each resistor. This can become difficult and time consuming with more complex circuits. It is sometimes more efficient to use a **current divider rule**. Considering the following circuit, to determine the current I_x through any of the resistors (R_x), you can use the following equation (this equation can be derived using Ohm's law).

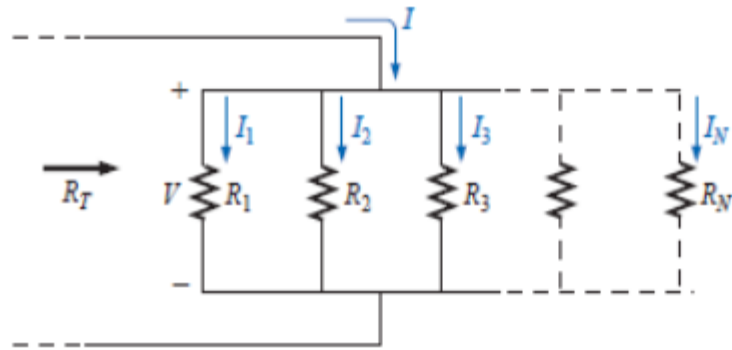

$$I_x = \frac{R_T}{R_x} I_T$$

Where:

- I_x is the current through a resistor R_x
- I_T is the total circuit resistance split amongst the parallel elements.

Question 3c

Question 3c of 6

Now using the same method shown on the previous slide, determine I_2 and I_3 for the circuit below.

$I_2 = 2A, I_3 = 6A$

$I_2 = 12A, I_3 = 6A$

✓ $I_2 = 6A, I_3 = 4A$

Correct

[Click here to continue](#)

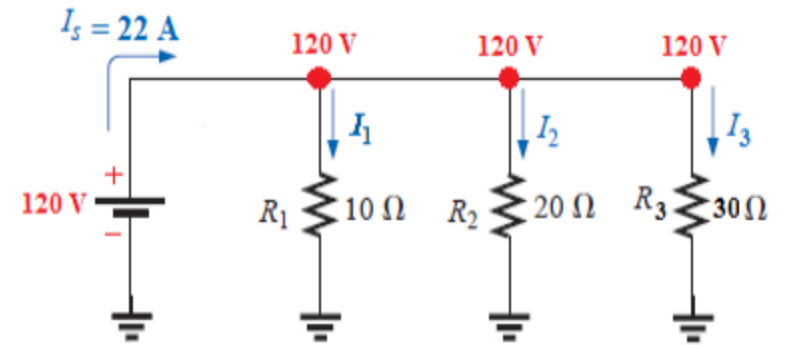

Current Divider Rule

A parallel circuit such as the figure shown below is often called a **current divider** for its ability to divide the total current I_T into fractional parts.

The ratio of total resistance (R_T) to individual resistance is the same ratio as individual (branch) current to total current. This is known as the current divider formula and it is a short-cut method for determining branch currents in a parallel circuit when the total current is known. If assume that $R_1=1$ kilo ohms , $R_2= 3$ kilo ohms, $R_3= 2$ kilo ohms and $I_T = 11$ mA, then,

$$I_1 = I_T R_T / R_1 = (11 \text{ mA} * 0.545 \text{ kilo ohms}) / 1 \text{ kilo ohms} = 5.99 \text{ mA}.$$

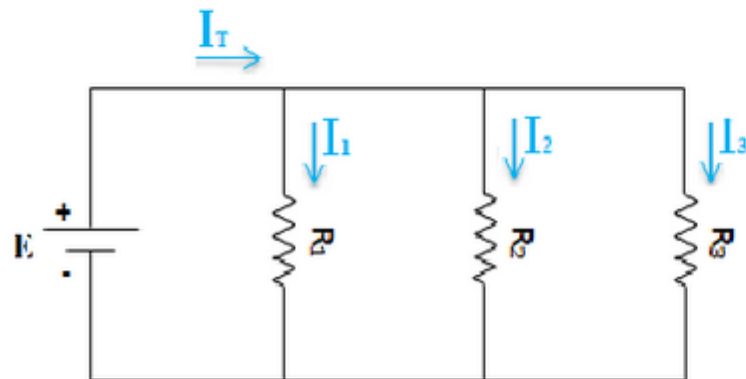

Current Divider Rule

Key things to remember:

- For two parallel elements of equal value, the current will divide evenly (for this case $R_1 = R_2$).
- For parallel elements with different values, the smaller the resistance, the greater its share of input current (for this case we assume $R_1 > R_2$, therefore it carries less current).

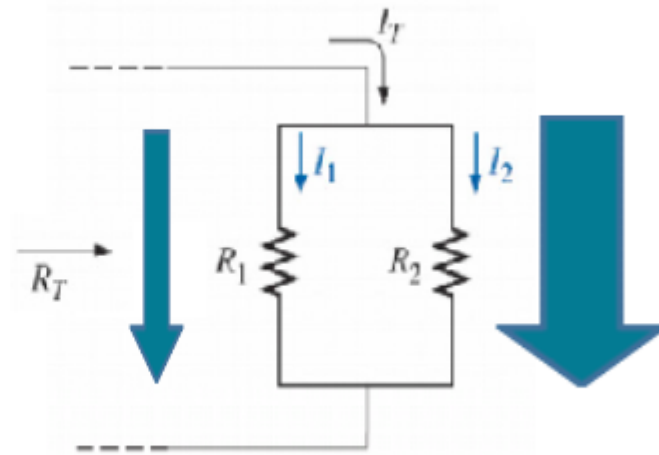
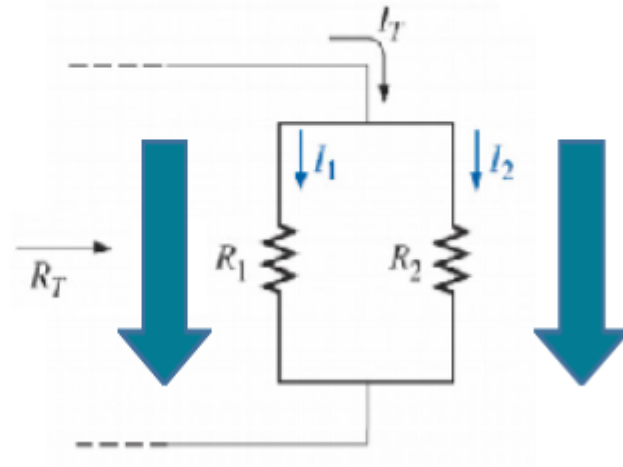

Question 4

Question 4 of 6

Which resistor will carry the largest amount of current in the circuit below?

The 6Ω resistor will carry the largest current

✓ The 2Ω resistor will carry the largest current

Current prefers to flow the path of least resistance, in this case, more current will flow through the 2Ω resistor compared to the 6Ω

Both resistors will carry the same current

[Click here to continue](#)

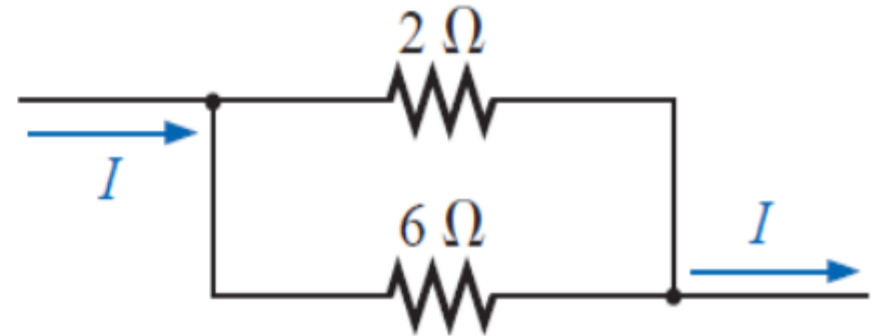

Current Divider

Consider the following circuit . Using the current divider rule, we will determine I_2 (recall $R_T = 5.4545\Omega$).

$$I_x = \frac{R_T}{R_x} I_T$$

$$I_2 = \frac{R_T}{R_2} I_T = \frac{5.4545 \Omega}{20 \Omega} \times 22 \text{ A}$$

$$I_2 = 6 \text{ A}$$

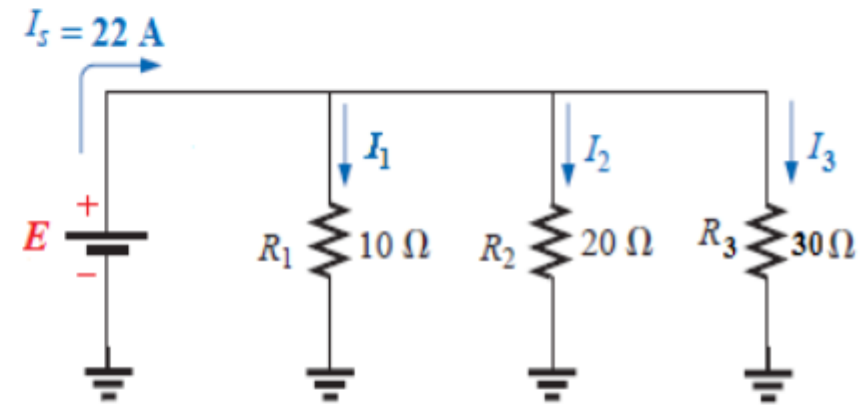

Note using the current divider we were able to eliminate a step of working and still obtain the same answer of $I_2 = 6 \text{ A}$.

Question 5

Question 5 of 6

Consider the following circuit, which resistor will carry the smallest current; R_1 , R_2 or R_3 ?

R_1

R_2

✓ R_3

Correct - Resistor R_3 has the highest resistance and therefore will carry the smallest current

[Click here to continue](#)

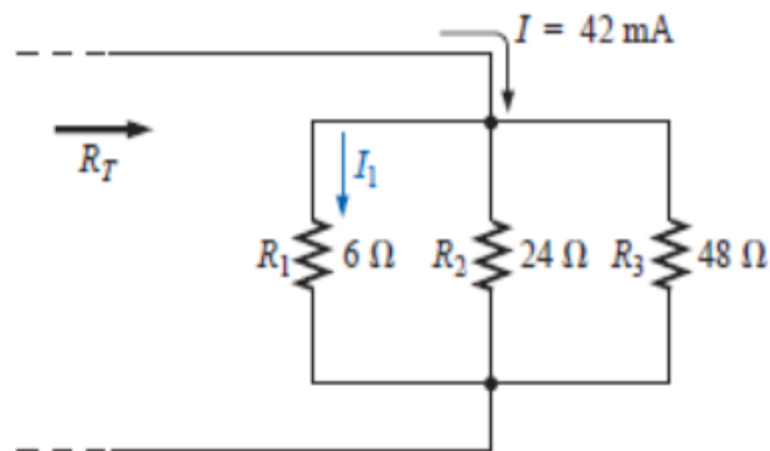

Question 6

Question 6 of 6

Using the current divider rule, determine the current I_1 through the 6Ω resistor?

3.82 mA

7.64 mA

✓ 30.52 mA

Correct: $R_T = R_1 // R_2 // R_3 = 1/(1/R_1 + 1/R_2 + 1/R_3) = 4.36$ ohm. Current through each branch. $I_1 = I_T R_T / R_1 = (42 \text{ mA} * 4.36 \text{ ohm}) / 6 \text{ ohms} = 30.52$ mA.

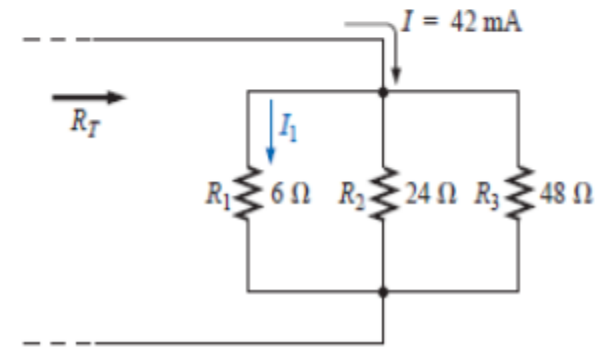

[Click here to continue](#)



Summary

Kirchoff's Current Law

- Algebraic sum of currents entering and leaving a junction (or node) within a network is equal to Zero.
- Sometimes easier to think of it as currents entering a node equal the currents leaving a node.
- Two variations of the same equation.

$$I_a = I_b + I_c + I_d$$

$$I_a - I_b - I_c - I_d = 0$$

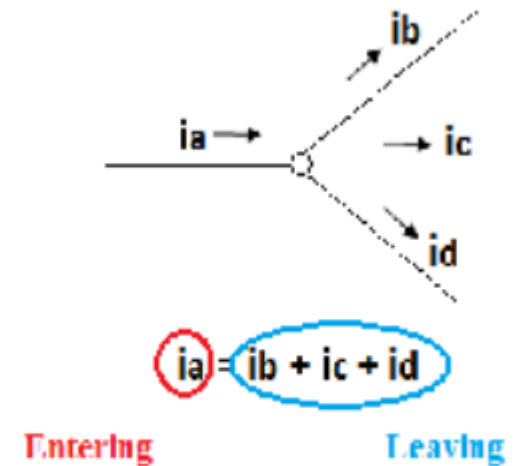

Summary (cont)

Current Divider

- Can be used to find current through an individual branch in a parallel circuit.
- First need to calculate total circuit resistance R_T .
- R_x is the resistor you wish to find the current through.
- Eliminates the need to find the voltage across the resistor to calculate current.

$$I_x = \frac{R_T}{R_x} I_T$$

Module Completed